



PILOT APPLICATION ON SOLAR ENERGY COMBINED ELECTRICITY GRID TO A RURAL WATER SUPPLY STATION IN CAN THO CITY

Le Anh Tuan

Research Institute for Climate Change, Can Tho University, Vietnam

ARTICLE INFO

Received date: 25/01/2016

Accepted date: 08/07/2016

KEYWORDS

Clean Development Mechanism, Greenhouse-gas emission, Solar energy, Water supply

ABSTRACT

Since 2008, a Clean Development Mechanism project, which can be counted towards meeting Kyoto targets, has been formed by Japan International Research Center for Agriculture Sciences and Can Tho University (JIRCAS-CTU). In this project, My Phung Hamlet, My Khanh Village, Can Tho City was chosen to implement a greenhouse-gas emission reduction model. One of the activities of the project, a domestic water supply plant was surveyed, designed and installed. A part of electricity sources used for plant operation is generated by solar panels. The selection of renewable energy is to fit the objectives of JIRCAS-CTU Project.

The project objective is to introduce of renewable energy for My Phung Water Supply Station by selecting one of the natural unpolluted, clean and rich energy resources such as bio-gas, wind, river flow and solar. The research has begun by surveying works, including the workshop results, water sampling and quality analysis, selection of water source alternatives, and design drawings of water supply and power application alternatives. In My Phung Hamlet's drinking water supply plant, water input for the plant is taken by a deep groundwater well and the power for the pump supplied partly by solar energy combined electricity grid system. Finally, some recommendations after the plant construction and pipelines are given for a future greenhouse-gas emission research and management. It is found that solar energy application is a new approach for local conditions and fitting the purpose of CDM objectives. However, the cost of solar panels is still high that leads to a limitation for the implementation if the financial is shortage.

Cited as: Tuan, L.A., 2016. Pilot application on solar energy combined electricity grid to a rural water supply station in Can Tho city. Can Tho University Journal of Science. Special issue: Development of Renewable Energy for the Mekong Delta: x-x.

1 INTRODUCTION

The Clean Development Mechanism (CDM) (UNEP, 2008) allows industrialized countries, in the list of Annex I under the Kyoto Protocol (UNFCCC, 1998) with a high greenhouse-gas (GHG) emission to carry out emission-reduction projects

in developing countries as an alternative to more expensive emission reductions in their own countries. Such projects can earn saleable certified emission reduction (CER) credits, each equivalent to one tone of CO₂, which can be counted towards meeting Kyoto targets. Japan International Research Center for Agriculture Sciences (JIRCAS)

has collaborated with Can Tho University (CTU) under the project for the Study of feasibility Sustainable Rural Development Based on Clean Development Mechanism in the Mekong Delta of Vietnam. The project introduced and developed the biogas digesters (B) as an added part to the VAC farming system (V: orchard garden; A: fish pond and C: animal husbandry;) becoming VACB (or Vuon-Ao-Chuong-Biogas in Vietnamese) system. The result of the project is considered as one basic technical concept for CDM. Since 2008, a CDM project has been formed by JIRCAS and CTU, in which My Phung Hamlet, My Khanh Village Phong Dien District, Can Tho City was chosen to implement a GHG emission reduction model.

My Phung is a hamlet located in My Khanh Village; Phong Dien District belonging to Can Tho City, as location presented in Figure 1. According to the statistical data on 2008 of the People's Committee of My Khanh Village, My Phung Hamlet is a rural area with 160 ha of land of which 105 ha is orchard lands, 15 ha is rice fields and 40 ha of surface water area. The whole My Phung Hamlet has 272 households with a population of 1,137 people. Most of the people living in My Phung are farmers. They cultivate rice, vegetables and upland crops, fruits,... and raise pig and fish. Otherwise, some of them have small business, agricultural service, and family handicraft.

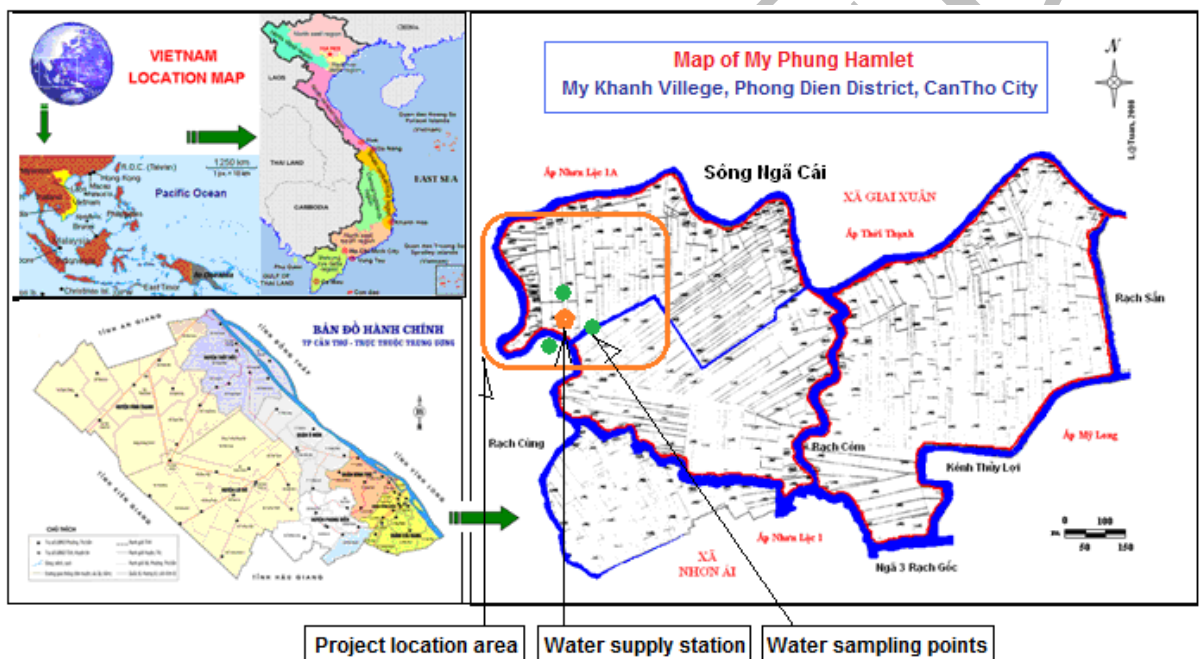

Fig. 1: Water supply project location in My Phung Hamlet, My Khanh Village

(Source: Location maps of Vietnam and Can Tho collected by Can Tho University and the map of My Phung Hamlet developed by author)

Based on an agreement between JIRCAS and CTU, a pilot project on water supply was done in My Phung Hamlet as one of project components, as well as the study site to contribute to the sustainable development of this area. The activities agreed in the project are to survey, design and build a water supply station operated by a solar energy combined electricity grid system as a pilot case study. The local water supply station in My Phung Hamlet was built for providing cleaning water about 130 households nearby. Water source for the station is taken from ground water well. Ground water

is pumped directly to the filtering sand tank. Finally, the treated water is pumped to store on the metal water tower for distributing to the consumers. The water tower is 10 meter height. The structure scheme of the treatment operation is presented in Figure 2. The survey and design of the water supply system in My Phung Hamlet was done in the end of the year 2009 in the framework of JIRCAS-CTU project (Tuan *et al.*, 2008). The water supply station was built in 2010. The maximum daily discharge of the water supply station is designed as 50 m³ per day. There are two pumping energy con-

sumption requirement, i.e. primary pump for pumping water from groundwater well to water supply plant and secondary pump for pumping

water from plant to the water tower for pipeline distribution.

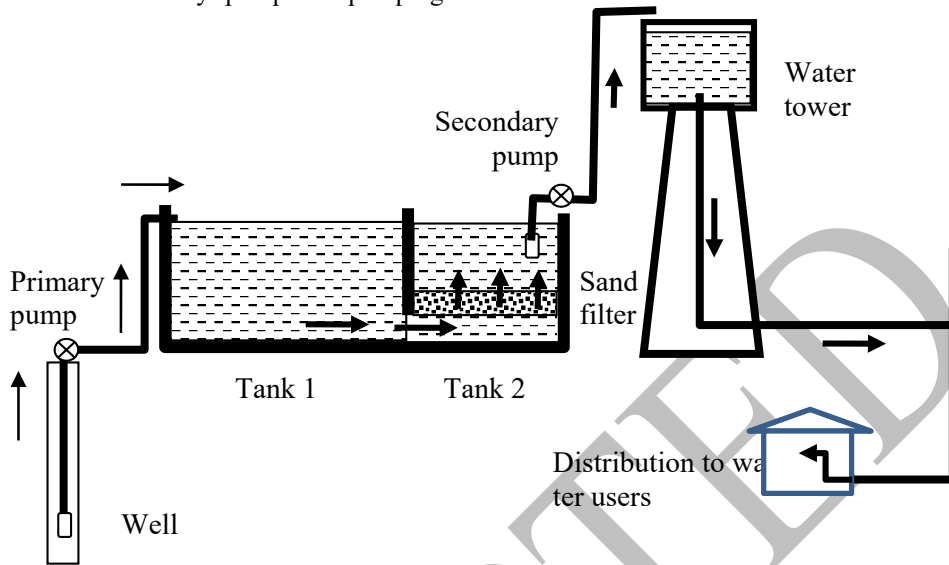

Fig. 2: Structural operation scheme of the existing water supply station

2 RESEARCH APPROACH

One of research activities of the project was to provide natural unpolluted, clean and rich energy resources such as bio-gas, wind, river flow and solar power to the water supply systems in My Phung. The general approach for steps on selection of renewable energy sources, technical design and cost

estimation for final approval before installation and operation can be presented as Figure 3. The selection renewable energy alternatives was done through a rapid comparison by Experts Opinion Method. Individual experts can be consulted to assist in finding the advantages/disadvantages in each option and then making the best decision fitting practicability criteria.

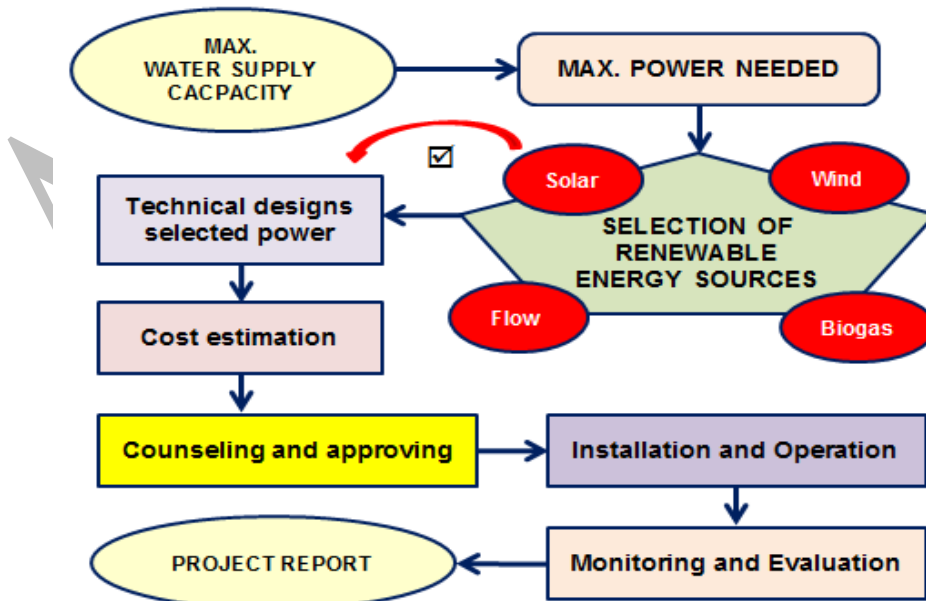

Fig. 3: General research approach and renewable energy chosen

The selection of renewable energy is to fit the objectives of JIRCAS-CTU Project. However, the application of renewable energy is constrained by the size, the investment cost, technology and management in the local conditions of My Phung commune. This problem can be solved if JIRCAS-CTU Project has a plan to upgrade the maintain capacity for local people. Solar power is very useful for water supply systems. The best fit for water supply system was determined to be a solar system.

Solar photovoltaic (PV) cells are promising for clean energy production, possible to provide the energy for all the water pump needs. Photovoltaic is understood as a generating electric power method to convert solar energy into a flow of electrons. Although in Can Tho Hydro-Meteorological Station has recorded the most accurate information of daily solar radiation, however, these data are difficult to collect and to analyze. In this study, a series of sunshine duration in hours per day, measured by Campbell–Stokes recorder, is to apply. In 2003, the sunshine duration was finally defined as the period during which direct solar irradiance exceeds a threshold value of 120 W/m² (WMO, 2008). For finding the relationship between a number series of daily sunshine and the maximum daily power obtained to batteries, two times series was collected as solar radiation recorded data and an on-site automatically charge controller (using FLEXmax 60). Charge controller FLEXMAX 60 (OutBack Power Technologies, 2012) use continuous Maximum

Power Point Tracking (MPPT), which seeks out the maximum power available from a PV array and uses it to recharge the batteries. Without this feature, the PV array does not operate at the ideal voltage and can only operate at the level of the battery voltage itself. In FLEXMAX, last 128 days of operational data are logged for reviewing.

3 RESULTS AND DISCUSSION

In My Phung Water supply plant, there are two pumping energy consumption requirement, i.e. primary pump for pumping water from groundwater well to water supply plant and secondary pump for pumping water from plant to the water tower for pipeline distribution. Table 1 is the required power, including primary pump and secondary pump. Power calculation is used for determination the pumping energy. Table 2 is total power calculation from the results from Table 1. In this case, the domestic power consumption for management purpose is not counted. Table 3 is a rapid comparison for selection renewable energy alternatives for water supply plant. Comparing advantages and disadvantages among 4 energy sources, it is possible to choose solar energy for pumping, as well as for suitable with the project objective. In this case, photovoltaic or solar electric panels are applied: these panels transform the solar radiation directly into electricity. A solar power system combined regional electricity grid system for My Phung Water supply plant is designed as the conceptual scheme in Figure 4.

Table 1: Power required for water supply system

Discharge Q _d (m ³ /d)	K _{dmax}	Q _{dmax} (m ³ /d)	Pump Capacity (m ³ /h)	Water Head (m)	Efficiency coefficient	Power (kW)	Power (HP)
Primary pump							
42.48	1.20	50.976	2.126	30	0.8	0.217	0.291
Secondary pump							
42.48	1.2	50.976	2.974	13	0.8	0.132	0.177

Table 2: Total power required for 2 pumps

1st Pump Power (kW)	2nd Pump Power (kW)	Required Power (kW)	1st Pump Power (HP)	2nd Pump Power (HP)	Required Power (HP)
0.217	0.132	0.349	0.291	0.177	0.468

Table 3: Rapid comparison for selection renewable energy alternatives

Energy sources	Advantages	Disadvantages
Biogas	<ul style="list-style-type: none"> To create favorable conditions for animal husbandry Having organic fertilizer for plant 	<ul style="list-style-type: none"> High investment Hardly management Unstable supply May create greenhouse gas (GHG)
Wind	<ul style="list-style-type: none"> Not to create GHG 	<ul style="list-style-type: none"> High investment To create noise in operation Unavailable when wind speed less than 2 m/s as in CanTho
River flow	<ul style="list-style-type: none"> Not to create GHG 	<ul style="list-style-type: none"> High investment To limit river navigation Unavailable when flow velocity less than 3 m/s as in CanTho
Solar	<ul style="list-style-type: none"> High sunshine in CanTho Easy to manage Not to create GHG Modern 	<ul style="list-style-type: none"> High investment

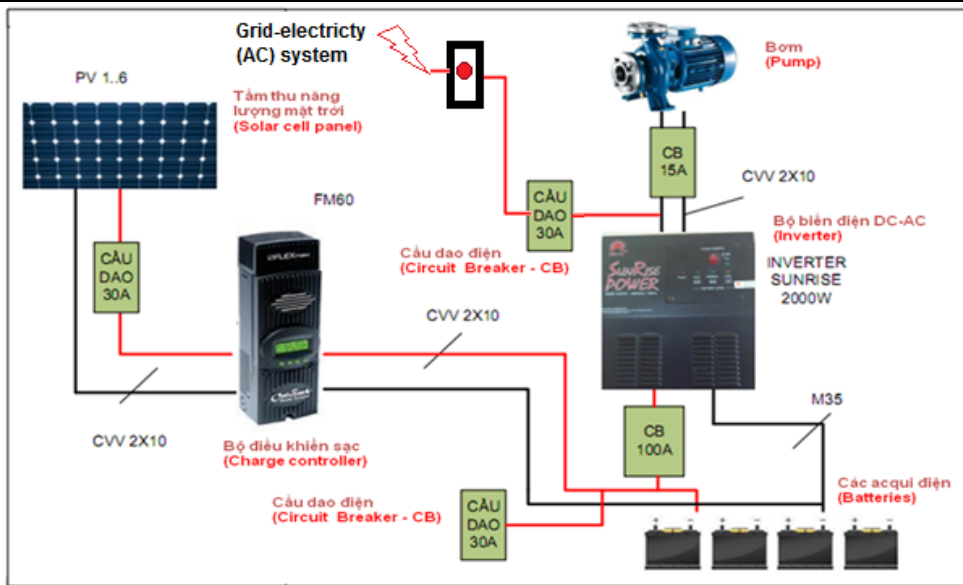

Fig. 4: Conceptual scheme of My Phung Water Supply Plant's solar power system

Beside the solar source, it is need to install the grid electricity to the plant as an added power source. The grid electricity will be used in case of lacking sunshine in rainy days or in case of solar repair. The power required for 2 pumps:

$$0.468 \text{ HP} = (0.468 \times 746) \text{ W} = 348.89 \text{ W}$$

The actual power required for starting engines: $348.89 \text{ W} \times 1.5 = 523.34 \text{ W}$ (The starting coefficient is assumed as 1.5 times the normal power required). Selecting mono-crystalline solar cell panel14 with capacity 280 W, size (1950 x 990 x 46) mm, so the number of solar panel is rounded

up as $(523.34/280) = 2$ solar cell panels. For safety reason for spare one, it is need to increasing 1 more solar panel in installation. So, the total solar panels for the water supply station are chosen as 3.

The price of solar panel is estimated as 4 USD/W approximately (not including the batteries, inverters, electricity lines, ...). This cost was still high that leads to a limitation for the implementation if the financial is shortage. However, solar energy application is a new approach for local conditions and fitting the purpose of CDM and JIRCAS-CTU objectives. So, the cost of 3 solar panels was accepted to install with a total price of 80 million

Vietnamese Dongs. The power supply system has been installed and operated since late 2010.

In a rapid estimation, there is a closed linear correlation between monthly average of daily sunshine hour and daily solar radiation in Can Tho City (Figure 5). Based on automatically measurement recorded by charge controller FLEXMAX 60 and

sunshine hours provided by Can Tho Hydro-Meteorological Station, it is found that there is a significantly power correlation between two data series, i.e. Maximum battery voltage obtained and number of sunshine hours measured to the time as presented in Figure 6 and Figure 7.

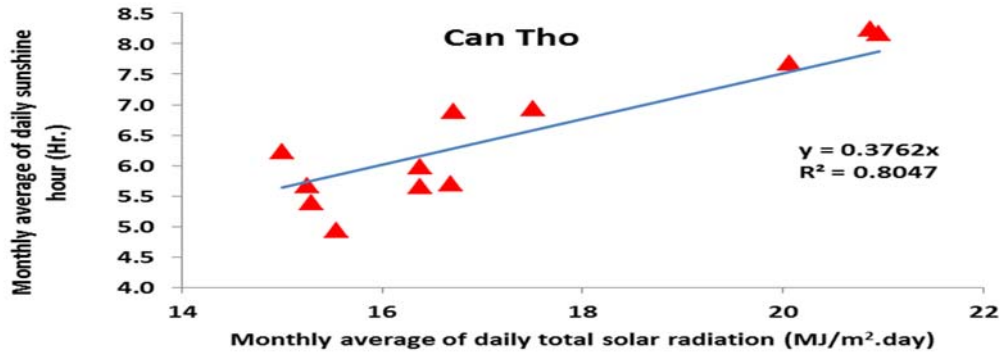

Fig. 5: Linear correlation between daily sunshine hour and daily solar radiation in Can Tho

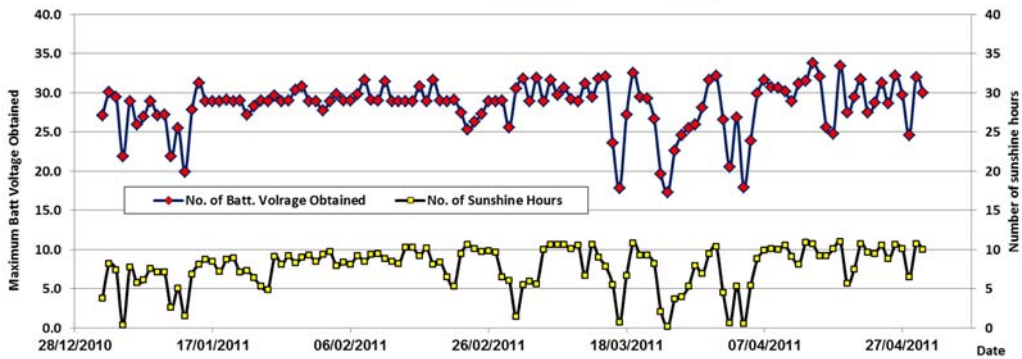

Fig. 6: Maximum Battery Voltage obtained vs. No. of sunshine hours measured in site

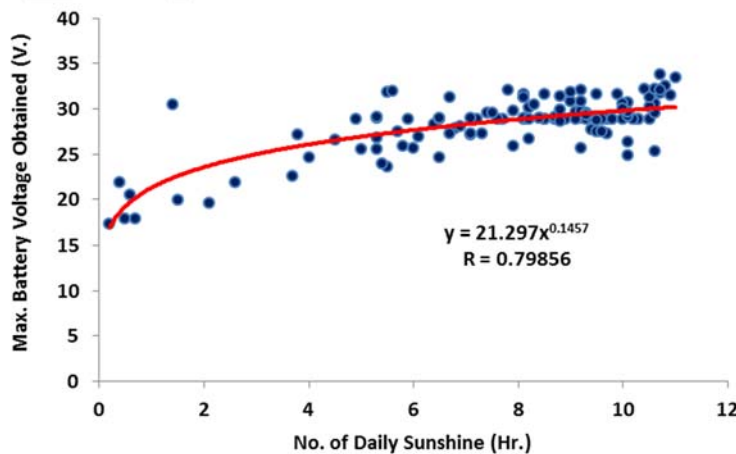

Fig. 7: Power correlation trend curve between in site max. Voltage and sunshine duration

4 CONCLUSION

During 4 months periods in the dry season of 2011, experiment results have shown that daily sunshine hours effect on PV electrical energy generation. PV system in My Phung could reach a highest power production value when getting a 8-10-hour sunshine per day in the dry season. On some cloudy days, power energy was still produced partly.

Solar energy application is considered as a sustainable green revolution. Overall, the solar power system in My Phung Water Supply Plant has worked well after two-year operation. The maintenance of solar panels comes with no significant complexities to local people, the daily operation risk is found nothing.

Although initial installation costs for solar PV is rather high if compared with electricity grid source using in the short time. However, for a long time, after 15 years operation, the cost for solar PV application is roundly estimated as equivalent with the electricity grid payment. It is providing virtually no environmental pollution impact and very fitting with the CDM's expectation. The decision to apply on solar power comes from its exceptional performance in several of the main success criteria for the JICAS – CTU project. In the future, if production technology in solar PVs is improved, the manufacturing and installation costs of PV panels will be reduced. The application this renewable

energy source become reliability for the rural and remote areas.

ACKNOWLEDGMENT

This research was financial supported by the Japan International Research Centre for Agriculture Sciences (JIRCAS).

Author thanks colleagues from the College of Environment and Natural Resources, as well as the local people in My Phung Hamlet, who collaborated and assisted during the project implementation and operation.

REFERENCES

- OutBack Power Technologies. 2012. FLEXmax Series Charge Controllers (FLEXmax 80, FLEXmax 60) Owner's Manual. 120p.
- Tuan, L.A., Nam, V.V., Du, L.V., Duc, N.H., 2009. My Phung Infrastructure Survey Report. JIRCAS-CTU Project, Can Tho University, Project technical Report, 59p.
- UNEP. 2008. Introduction to the Clean Development Mechanism. Available at: http://unfccc.int/files/cooperation_and_support/capacity_building/application/pdf/unepcdmintro.pdf.
- UNFCCC. 1998. Kyoto Protocol to the United Nations Framework Convention on Climate Change, available download on: <http://unfccc.int/resource/docs/convkp/kpeng.pdf>.
- WMO. 2008. Guide to Meteorological Instruments and Methods of Observation. Chapter 8: Measurement of Sunshine Duration.